

Dynarail® Guardrail, Handrail & Ladder Products Brochure

Fibergrate Composite Structures

High Performance Composite Solutions



High Performance Composite Solutions

Dynarail® FRP Products

Combining corrosion resistance, long life and a low maintenance design, Dynarail® guardrail, handrail and ladder systems are superior to conventional metallic systems. These advanced systems are designed and manufactured to be easily installed with no guesswork involved. Components are lightweight and easy to fabricate. Savings on labor and equipment often make the total installed cost of Dynarail comparable to that of steel. Combining its low cost of installation with low maintenance and long life, Dynarail offers a life cycle cost that is significantly lower than that of its counterparts.



The Dynarail guardrail line includes everything needed to install OSHA- and IBC-compliant horizontal and inclined railing systems with either two or three rails. Fiberglass can also provide specialty picketed guardrail systems. The Dynarail handrail system can be added to a guardrail or wall to meet code requirements. The Dynarail ladder line includes ladders, standard walk-thrus and safety cages. Fiberglass's complete line of Dynarail products offer a variety of solutions for most applications.

Dynarail components including the railing, kickplate and ladder rungs, are manufactured using the proven Fiberglass pultrusion process. In this process, continuous fiber rovings and mat as well as a synthetic veil are mechanically drawn through a resin bath and shaped through a series of forming guides, then pulled through a heated die.



[Fiberglass Markets]

- Architectural
- Bridge & Highway
- Chemical
- Commercial
- Food & Beverage
- Manufacturing
- Metals & Mining
- Microelectronics
- Oil & Gas
- Pharmaceutical
- Power
- Pulp & Paper
- Recreation
- Telecommunications
- Transportation
- Water & Wastewater

Dynarail® Benefits



Corrosion Resistant:

Dynarail® fiberglass guardrail, handrail and ladder products are known for their ability to provide corrosion resistance in the harshest environments and chemical exposures.



Slip Resistant:

Ladder rungs include heavily serrated flutes for positive, slip resistant footholds; also ungritted rungs are easy on the hands, while still ensuring safety.



Low Maintenance:

The corrosion resistant properties of Fibergrate's FRP products reduce or eliminate the need for sandblasting, scraping and painting. Products are also easily cleaned with a high pressure washer.



Fire Retardant:

Flame spread rating of 25 or less, as tested in accordance with ASTM E-84, and meets the self-extinguishing requirements of ASTM D-635.



Electrically & Thermally Non Conductive:

Fiberglass is electrically non conductive for safety and has low thermal conductivity which results in a more comfortable product when physical contact occurs.



Long Service Life:

Fiberglass products provide outstanding durability and corrosion resistance in demanding applications, therefore providing improved product life over traditional materials.



Low Install Cost:

Due to ease of fabrication and light weight, FRP guardrail, handrail and ladders eliminate the need for heavy lifting equipment. Components are also labeled with tags that correspond to engineering drawings to ensure time-efficient and accurate installation.



UV Protection:

UV inhibitors in the resin matrix, along with a synthetic surfacing veil, provide optimum protection from the effects of UV weathering. *(An optional UV coating is required for installations with intense UV exposure.)*



NSF® Standard 61-Certified:

Fibergrate is now able to offer NSF Standard 61-Certified Dynarail® FRP guardrail, handrail and ladder systems. These products complement the complete line of NSF Standard 61-Certified Fibergrate® molded gratings, Dynaform® fiberglass structural shapes, and Safe-T-Span® pultruded gratings assembled from NSF Standard 61-Certified components. Molded gratings are available in all Fibergrate® molded grating mesh patterns and thicknesses, except 4' x 12' Micro-Mesh® panels.



Heavy Metal Safe:

The EPA, OSHA and other regulatory agencies created to protect our lives and our natural resources have increased legislation to control heavy metals such as lead, chrome, cadmium and other metals in all products where exposure is a health threat. Fibergrate Composite Structures Inc. supports this strengthened legislation and has, for more than 20 years, voluntarily tested for heavy metals in our products and minimized or eliminated heavy metals from our products.

[Dynarail Resin Systems]

- **ISOFR (Guardrail, Handrail and Ladders):**
Isophthalic polyester resin formulation with a low flame spread rating of 25 or less designed for applications where there is moderate exposure to corrosive elements.
- **VEFR (Guardrail, Ladders & Handrail):**
Vinyl ester resin system with a flame spread of 25 or less for dependable resistance to both acidic and alkaline environments.

Dynarail® FRP Guardrail & Handrail

[Dynarail Modular Guardrail and Handrail]

Dynarail modular guardrail and handrail provide the look and performance of a custom rail system in an easily assembled, cost-effective package. Available in easy-to-use kits, the modular kits include step-by-step installation instructions.

Dynarail is expertly engineered to use the fewest number of railing components of any system available in order to facilitate an easier, faster installation with less chance of error. Kits include everything needed for a quality installation requiring only minimal assembly skills, less labour and common hand tools. Posts are pre-routed to accept continuous rails, eliminating the need for extra pieces to connect rails to posts. Utilizing modular kits eliminates time-consuming fabrication and field modification associated with using stock lengths.



[Dynarail Unique Guardrail and Handrail Solutions]



Fibergrate has the capability to turnkey (design, manufacture, fabricate and install) a wide range of railing projects, from the smallest platform to massive, complex structures; from basic stairways to ADA compliant systems. To meet the requirements presented by such projects, Fibergrate employs a staff of engineers and technicians highly experienced in computerized design. This design group, well versed in all phases of FRP railing mounting conditions and special connections, provides the Fibergrate customer with accurate, concise drawings that meet the specifications of the project.

Fibergrate can also offer design, engineering, fabrication, and installation of specialty solutions and picketed guardrail, segmented platform railings and other special systems.

Dynarail® Post Installation Methods

See page 7 for part numbers. For installation conditions not shown, contact Fibergate. All details are for posts spaced 6' max on centers to meet a F.O.S. of 2.0 under OSHA and IBC loads, unless noted otherwise.

DRAWING A - POST TO FRP OR STEEL CHANNEL

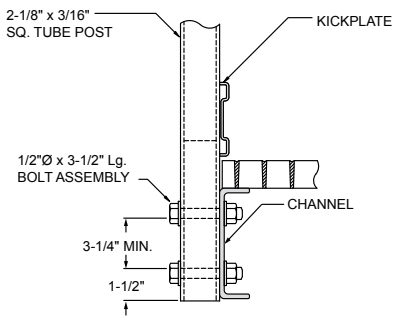

DRAWING B - POST TO STEEL PLATE ON STEEL BEAM

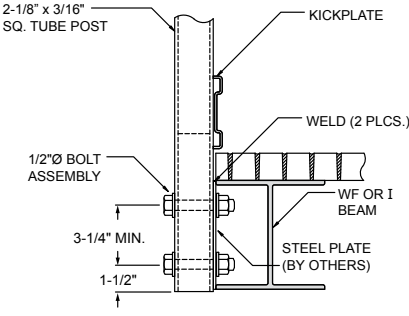

DRAWING C - POST TO FRP OR STEEL BEAM OR CHANNEL WITH FRP SPACERS

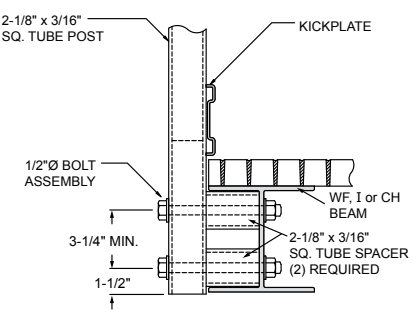

DRAWING D - POST TO STEEL ANGLE ON FRP OR STEEL BEAM

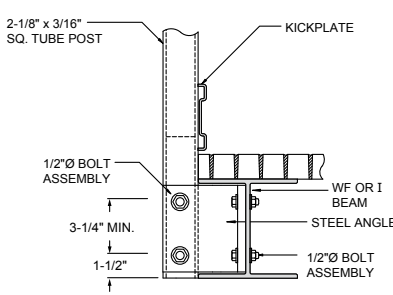

DRAWING E - REMOVABLE POST TO FRP OR STEEL BEAM

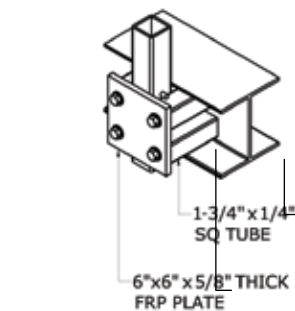

DRAWING F - SIDE-MOUNTED POST

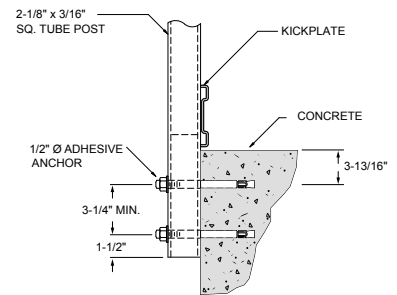

DRAWING G - EMBEDDED POST

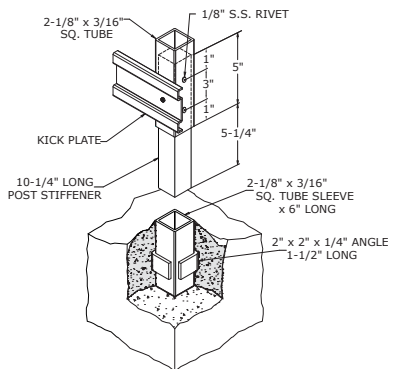

DRAWING H - TOP MOUNT STAINLESS STEEL STANCHION BASE

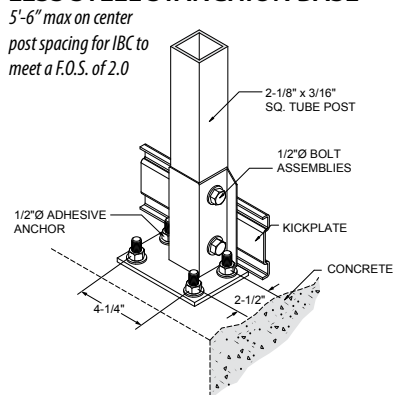

DRAWING I - TOP MOUNT FRP STANCHION BASE

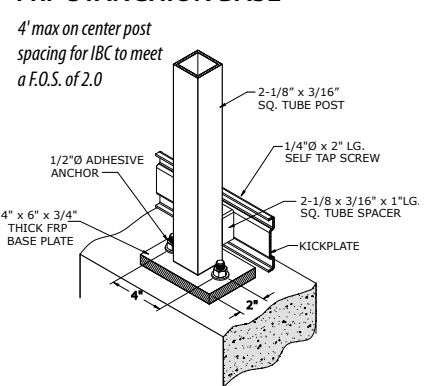

MAX PULLOUT FORCE ON EACH CONCRETE ANCHOR BOLT			
	Drawing F	Drawing H	Drawing I
OSHA (200lb)	2129 lbf	1292 lbf	2100 lbf
IBC (50 lb/ft)	3193 lbf	1777 lbf	2100 lbf

Modular Dynarail® Guardrail & Handrail Systems

Both horizontal and inclined posts and rails are permanently joined using rivets and an epoxy compound. Dynarail modular rails can be set at any angle to the post, from 39° to 180°, using supplied coverplates. Straight splice kits are equally easy to incorporate, joined by either a riveted connection or a nut and bolt assembly. Dynarail modular posts are designed for conventional side-mounting, and kits are also available for installation of either top-mount stanchion bases or removable concrete-embedded bases.

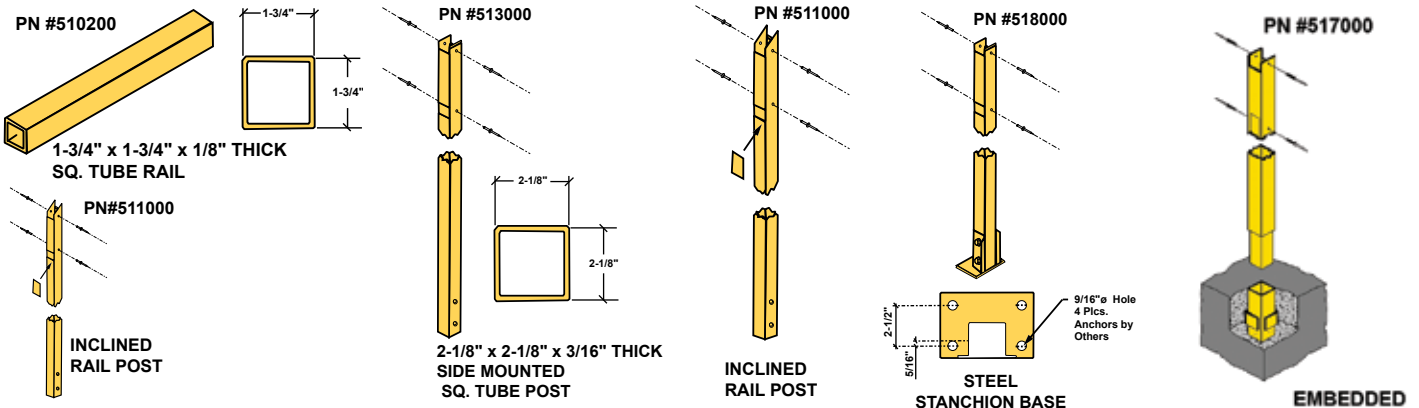
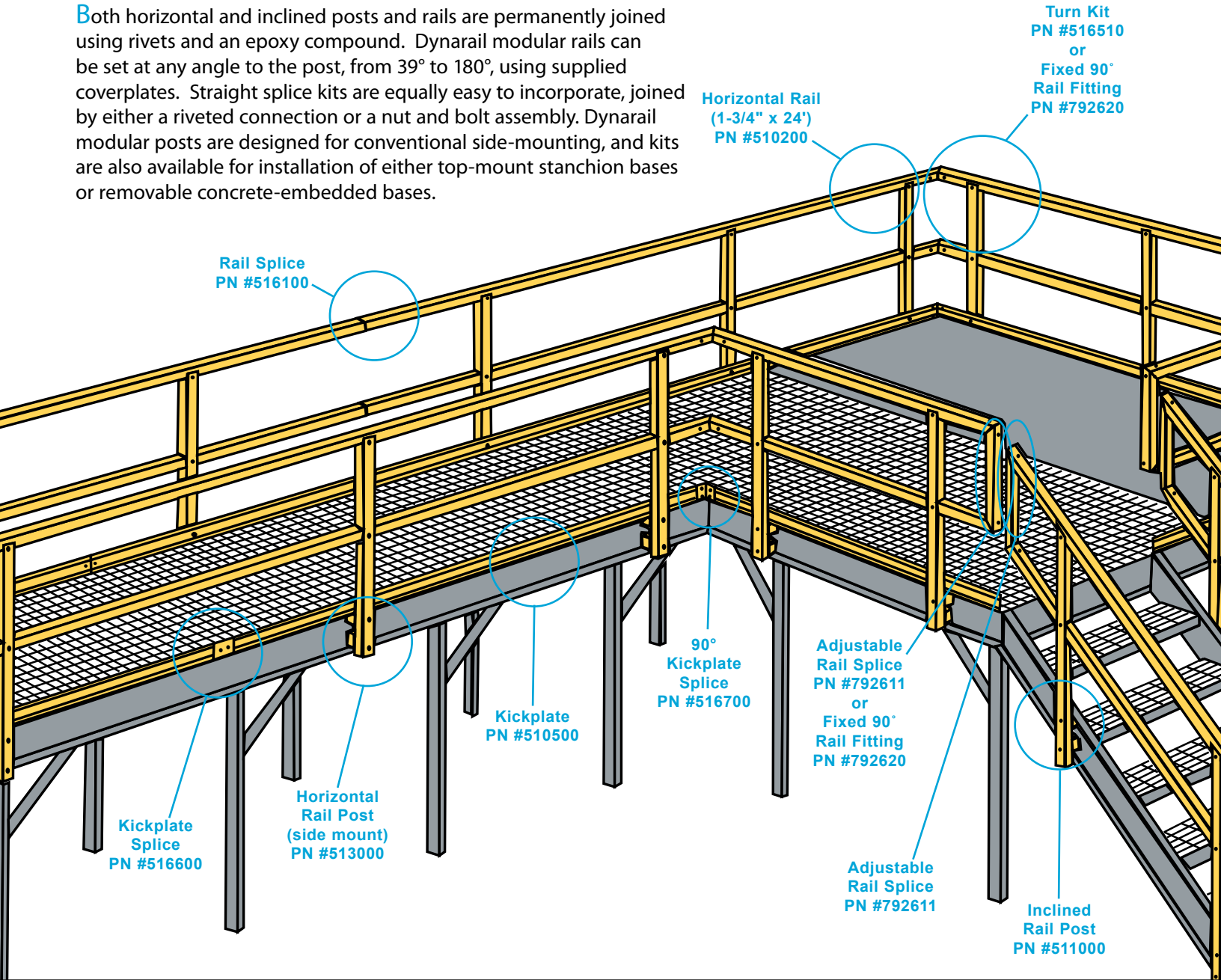

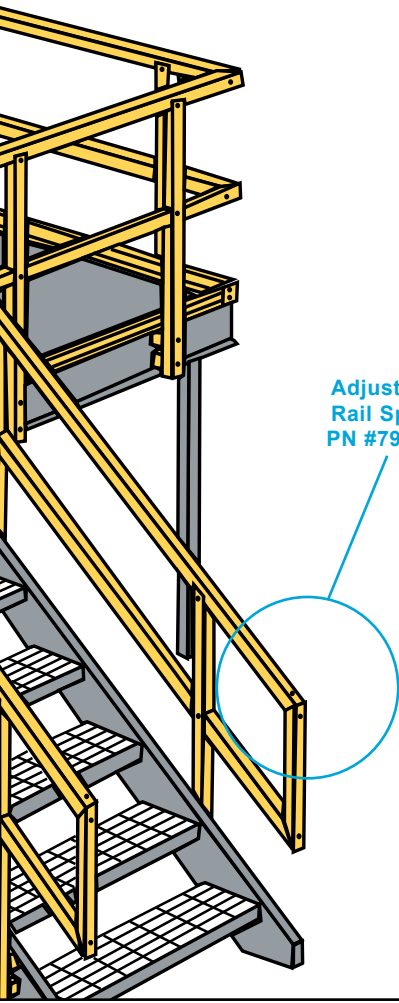

Adjustable Rail Splice
PN #792611

ASSEMBLY PART #		DESCRIPTION
510500	Kickplate	9/16" deep x 4" high x 1/8" thick x 24' long
516600	Kickplate Splice Kit	1 ea. Splice 1-3/4" x 4" x 3/16"
		2 ea. 1/4" x 1" x socket round head bolts, nuts and washers.
516700	Kickplate Splice Kit 90°	1 ea. Splice 2-1/8" x 1-1/8" x 3/16"
		2 ea. 1/4" x 1" x socket round head bolts, nuts and washers.
511000	Post Kit (Inclined Rail)	1 ea. Post 2-1/8" x 3/16" x 45" high sq. tube
		4 ea. Cover Plates 2-1/8" x 3-1/4"
		4 ea. Rivets 18-8 SS
513000	Post Kit (Horizontal Rail) Side Mount	1 ea. Post 2-1/8" x 3/16" x 50-1/4" high sq. tube (undrilled)
		4 ea. Rivets 1/8" x 3/8" 18-8 SS
		1 ea. #10 x 1" Hex Washer Head Self Tap Screw
517000	Post Kit (Horizontal Rail) Removable Concrete Embedded	1 ea. Post 2-1/8" x 3/16" x 41-1/2" high
		1 ea. 1-3/4" sq. bar extension 5" long
		1 ea. Sleeve 2-1/8" x 3/16" x 6" sq. tube (ships loose)
		4 ea. Rivets 18-8 SS
		1 ea. #10 x 1" Hex Washer Head Self Tap Screw
518000	Post Kit (Horizontal Rail) Top Mount (SS Base)	1 ea. Post 2-1/8" x 3/16" x 41-1/4" high
		1 ea. Stanchion Base 316 SS
		2 ea. Bolts 1/2" x 3" and nuts 316 SS
		4 ea. Rivets 18-8 SS
		1 ea. #10 x 1" Hex Washer Head Self Tap Screw
518200	Post Kit (Horizontal Rail) Top Mount (FRP Base)	1 ea. Post 2-1/8" x 3/16" x 40-3/4" high
		1 ea. Stanchion Base FRP
		1 ea 2-1/8" x 3/16" Sq. Tube Kickplate Spacer
		1 ea. 1/4" Hex Bolt Assembly
		4 ea. Rivets 18-8 SS
510200	Rail	1-3/4" x 1/8" x 24' long sq. tube
792611	Adjustable Rail Splice	1 ea. Adjustable from 39° to 180°
516100	Rail Splice Kit	1 ea. Splice 1-1/2" sq. tube
		4 ea. Rivets 18-8 SS
516510	Turn Kit	2 ea. Adjustable Rail Splices
		8 ea. Rivets 18-8 SS
510100	Spacer Material	21' of 2-1/8" x 3/16" yellow sq. tube
Bonding material should be ordered with each shipment of railing material. Order 1 kit (# 549100) for every 15 posts		
SI Conversions: inch = 25.4 mm 1 foot = .305 m 1 mm = .0394 inches 1 meter = 3.28 feet		

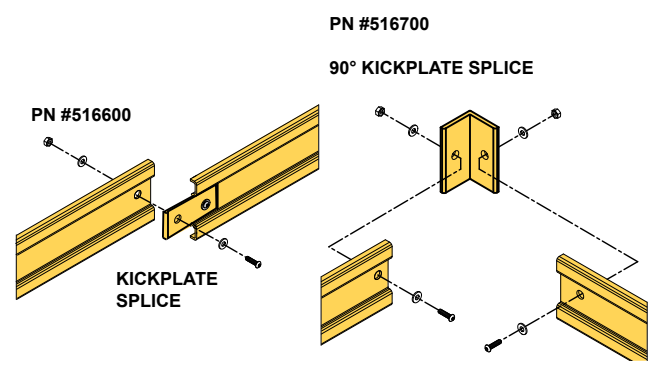
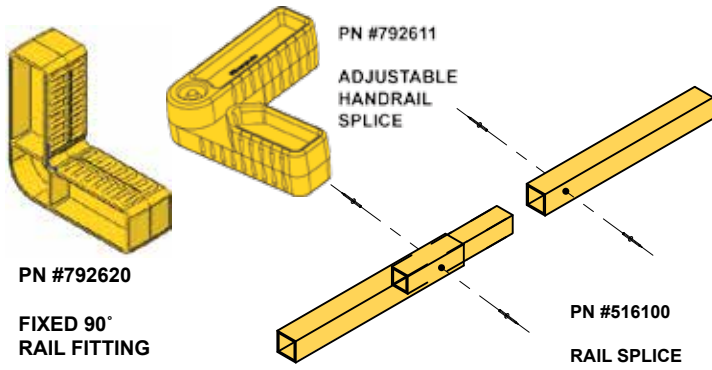

Modular Dynarail® Guardrail & Handrail Systems

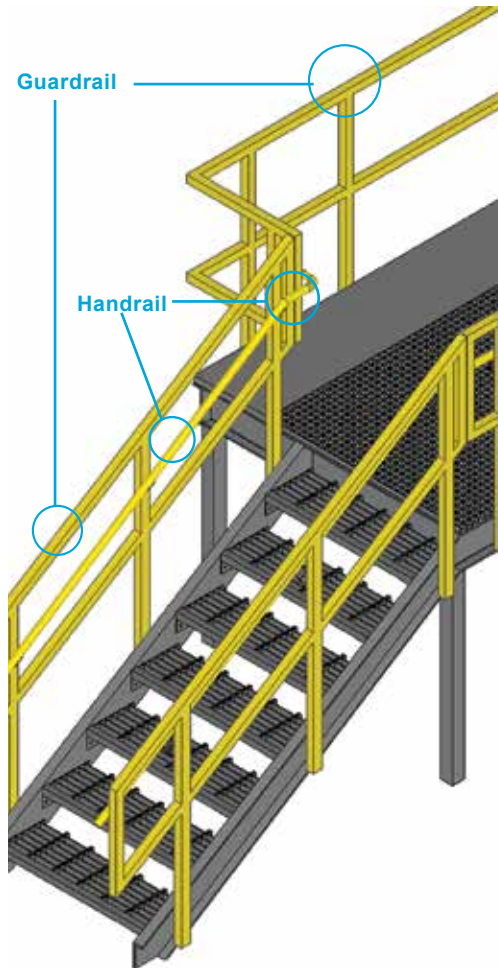

ASSEMBLY PART #	DESCRIPTION
162728	Rail used as Handrail 1-1/2" x 1/4" x 20' Long Yellow Round Tube
792650	Fixed 90° Handrail Connector
792640	Adjustable Handrail Connector 1 ea. Adjustable from 39° to 180°
522090	Handrail Splice - 1" Ø FRP Round Rod
792660	Handrail End Cap
794510	SS Handrail Bracket
794515	SS Backer Plate
756670	1 ea. #10 x 1" Hex Head Self Tap Screw
Bonding material (1 Kit - PN#549100) should be ordered with each shipment of handrail material.	
SI Conversions: inch = 25.4 mm 1 foot = .305 m 1 mm = .0394 inches 1 meter = 3.28 feet	

FIXED 90° HANDRAIL CONNECTOR
PN#792650



ADJUSTABLE HANDRAIL CONNECTOR
PN#792640



FIXED HANDRAIL CONNECTOR
PN#792650



ROUND TUBE
USED AS HANDRAIL

ADJUSTABLE HANDRAIL CONNECTOR
PN#792640

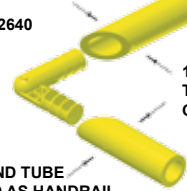

ROUND TUBE
USED AS HANDRAIL

HANDRAIL END CAP
PN#792660



HANDRAIL SPLICE
PN#522090

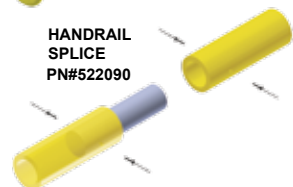

SS HANDRAIL BRACKET
PN#794510

SELF TAPPING SCREWS (PN#756670) ARE REQUIRED TO ATTACH SS BRACKET TO ROUND HANDRAIL TUBE

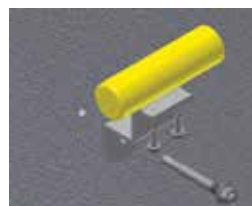

FOR ATTACHMENT TO A CONCRETE WALL:
PN#794510 REQUIRES 3/8" DIA. CONCRETE ANCHOR

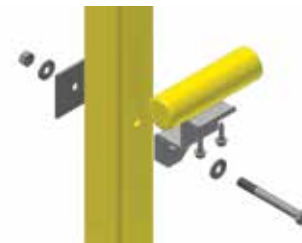

FOR ATTACHMENT TO AN FRP POST:
PN#794510 REQUIRES 3/8" DIA. HEX HEAD BOLT & SS BACKER PLATE (PN#794515) ON OPPOSITE SIDE OF POST TO PREVENT POST FROM BEING CRUSHED BY BOLT

Dynarail® FRP Safety Ladders

The innovative Dynarail® fiberglass reinforced plastic (FRP) safety ladder and cage system meets or exceeds OSHA requirements. Dynarail cage components are shipped in compact kit form - not large, bulky units prone to damage. The safety cage is ready for field assembly with predrilled hoops for fast and easy attachment to the ladder and vertical safety bars.

Ladders are stocked in standard heights of 8', 10', 12', 14', 16', 18', 20' and 24' and are available in taller heights using splice kits. Ladders may be ordered with or without safety cage kits.



Safety features are built in from the ground up. Special clip angles have been developed to securely anchor the ladder. Intermediate stand-off brackets laterally stabilize the ladder to the supporting structure on 6' centers. Ladder rungs include heavily serrated flutes for slip resistant footholds.

[Technical Data] *(Except where noted, all materials are yellow vinyl ester, fire retardant - VEFR)*

LADDER:

Maximum length without splice	24'-0"	Outside Diameter of rung	1-1/4"
Maximum ladder length with cage	33'-6"	Inside Diameter of rung	7/8"
Clear inside width (inside rail to rail)	18"	Rail - outside width	1-3/4"
Outside width (outside rail to rail)	21-1/2"	Rail - wall thickness	1/4"
Rung Spacing (center to center)	12"	Weight per foot (approximately)	2.7 lbs.

CAGE:

Product	Description
Standard Hoop Kit (PN 448200)	27" from center line of ladder rung to inside of hoop 3" wide x 1/4" thick hand layup Predrilled holes <i>(with necessary bolt assemblies)</i>
Bottom Hoop Kit (PN 448000)	31" from center line of ladder rung to inside of hoop 3" wide x 1/4" thick hand layup Predrilled holes <i>(with necessary bolt assemblies)</i>
Hoop Brackets (Included with hoop kits)	1/4" thick, "U" shaped hand layup Predrilled holes <i>(with necessary bolt assemblies)</i>
Vertical I-Bars (PN 446211 - 10 ft; PN 446210 - 20 ft)	I-Bar, 1-1/2" deep x 5/8" flange x 1/8" thick
Bottom Wall Mount Bracket Kit* (PN 448400 ISOFR Dk Gray, PN 448401 VEFR Beige) <i>Required when ladder cannot be floor mounted</i>	2-3/16" x 8" x 3/8" angle, 18" long Two per set <i>(with necessary bolt assemblies)</i>
Wall Mount Bracket Kit* (PN 448500 ISOFR Dk Gray, PN 448501 VEFR Beige)	2-3/16" x 8" x 3/8" angle, 6" long 7" from wall to center of rung Two per set <i>(with necessary bolt assemblies)</i>
Floor Mount Clip Kit* (PN 448700 ISOFR Dk Gray, PN 448701 VEFR Beige)	4" x 4" x 3/8" angle, 2-3/4" long Two per set <i>(with necessary bolt assemblies)</i>

***NOTE:** Wall mount brackets and floor mount clips are predrilled with 9/16" diameter holes for 1/2" diameter anchor bolts only. **Anchor bolts not included.**

Dynarail® FRP Safety Ladders

Dynarail® Ladder Systems Data

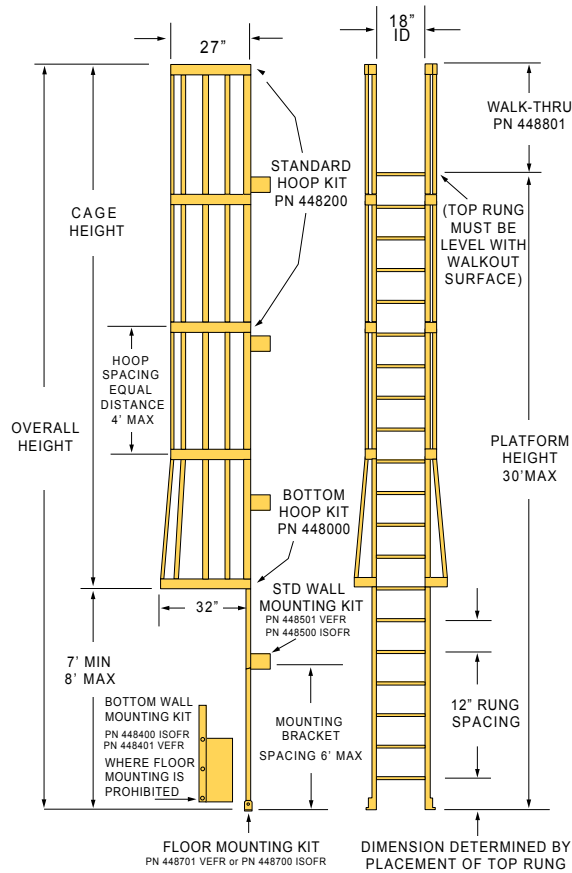

Component Selection Guide

Cage Assembly Components

Cage Height	Hoops Required		Vertical I-Bars Required	
	Standard Hoop Kit PN 448200	Bottom Hoop Kit PN 448000	10' Vertical I-Bar PN 446211	20' Vertical I-Bar PN 446210
3' 0"	1	1	3	0
3' 6" to 4' 0"	1	1	1	1
4' 7-1/2"	1	1	4	0
4' 7-1/2" to 5' 3"	2	1	4	0
5' 6"	2	1	4	0
6' 0" to 6' 6"	2	1	0	2
7' 0"	2	1	2	2
7' 6"	2	1	0	3
8' 0" to 8' 10-1/4"	2	1	7	0
8' 10-1/4" to 10' 0"	3	1	7	0
10' 6" to 13' 1"	3	1	0	5
13' 1"	4	1	0	5
13' 6" to 14'	4	1	3	4
14' 6" to 17' 3-3/4"	4	1	0	7
17' 3-3/4" to 20' 0"	5	1	0	7
20' 0"	5	1	0	7
20' 6" to 21' 7/12"	5	1	1	8
21' 7/12" to 22' 6"	6	1	1	8
23' 0" to 24' 0"	6	1	4	7
24' 6" to 25' 10-1/2"	6	1	1	10
25' 10-1/2" to 26' 6"	7	1	1	10

Ladder Mounting Accessories

Ladder Height	Floor Mount Kits Required PN 448700 ISOFR PN 448701 VEFR	Bottom Wall Mount Kits PN 448400 ISOFR PN 448401 VEFR	Wall Mount Kits Required PN 448500 ISOFR PN 448501 VEFR
0" to 6"	1	1	1
6' 6" to 12' 0"	1	1	2
12' 6" to 18' 0"	1	1	3
18' 6" to 24' 0"	1	1	4
24' 6" to 30' 0"	1	1	5
30' 6" to 36' 0"	1	1	6

Dynarail® Hoop Data

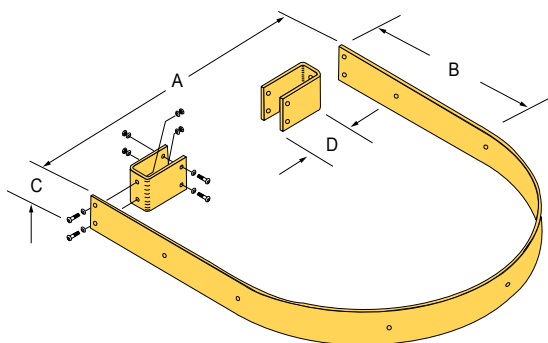

Hoop Kit	PART NUMBER	A	B	C	D
Bottom	448000	35"	16"	3"	8.5"
Standard	448200	27"	16"	3"	4.5"

Ladder and Accessories

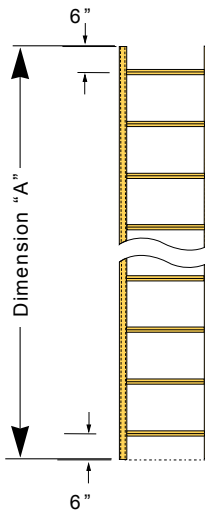

Ladders ("A" dimension = stock length)	
Length*	Part Number
8'	444508
10'	444510
12'	444512
14'	444514
16'	444516
18'	444518
20'	444520
24'	444524
Accessories	
Description	Part Number
Ladder Rail Splice Kit	448600
18" Wide Walk-thru Kit	448801
24" Wide Walk-thru Kit	448901

*Field Cut to size

Note: Top rung step-off must be even with upper walking surface

Dynarail® FRP Safety Ladders

[OSHA Requirements for Ladders & Ladder Systems]

From the Code of Federal Regulations, Title 29, Labor, 1910.27

Installer is responsible for referring to most current OSHA Code for complete information.

1. (a)(1)(i) 200 lb concentrated load (minimum at center of rung)
2. (b)(1)(ii&iii) Distance between rungs maximum 12", minimum clear width between siderails of 16"
3. (c)(4) Distance from the centerline of rungs to wall in back of ladder shall be not less than 7"
4. (d)(1)(ii) Cage required on ladders of more than 20' to a maximum unbroken length of 30'
5. (d)(1)(iii) Cage to extend minimum of 42" above top of landing
6. (d)(1)(iv) Cage shall begin minimum 7' to maximum 8' above base of ladder (floor)
7. (d)(1)(v) Cage shall not be less than 27" in width
8. (d)(1)(v) Cage hoop vertical bars shall be located at a maximum spacing of 40° around the circumference of the cage

[Assembly & Mounting Details]

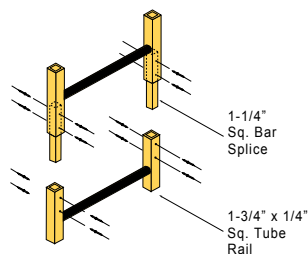

Ladder Splice Kit
PN 448600

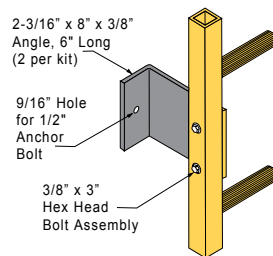

Standard Wall Mount Kit
PN 448501 VEFR BEIGE

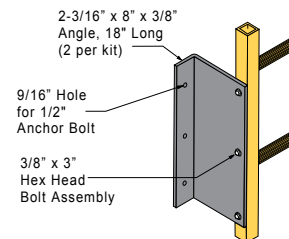

Bottom Wall Mount Kit
PN 448401 VEFR BEIGE

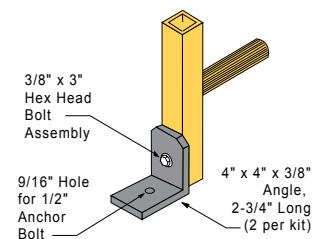

Floor Mount Kit
PN 448701 VEFR BEIGE

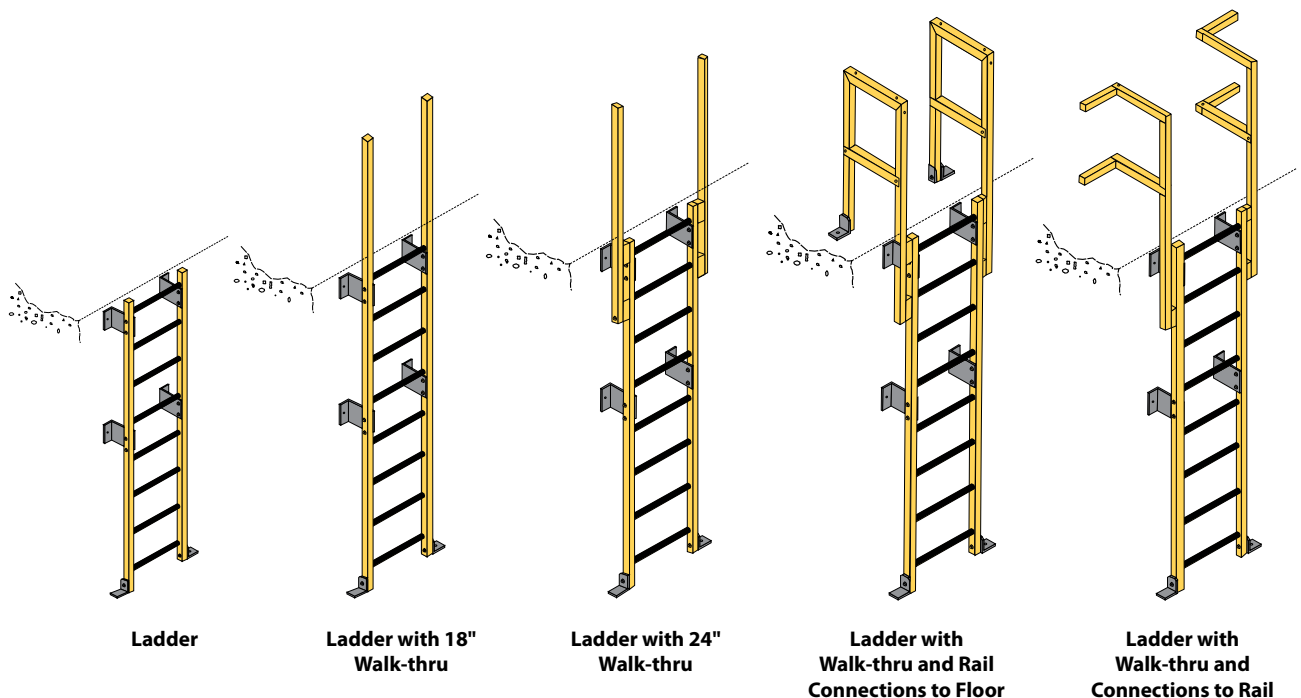

Ladder

Ladder with 18" Walk-thru

Ladder with 24" Walk-thru

Ladder with Walk-thru and Rail Connections to Floor

Ladder with Walk-thru and Connections to Rail

Contact

Fibergrate World Wide

Canadian Head Office
Whitby, Ontario, Canada

Canadian Design & Innovation Centre
Oshawa, Ontario, Canada

Canadian Fibergrate Manufacturing Centre
Oshawa, Ontario, Canada

U.S. Fibergrate Corporate Office
Dallas, Texas, USA

U.S. Fibergrate Manufacturing Facilities
Stephenville, Texas, USA
Querétaro, Mexico

International Sales and Service Offices
Monterrey, Mexico
Stockton on Tees, United Kingdom
Johannesburg, South Africa
Melbourne, Australia
Bogotá, Colombia
Buenos Aires, Argentina
Dubai, U.A.E.
Shanghai, China

Customer Sales and Service Contact
800-263-3112 (Toll Free)
905-430-3333

Visit us on our website
www.fibergrate.ca

Fibergrate Canada

Vancouver	Saskatoon	Whitby	Montréal	St. John's
Victoria	Regina	Kingston	Québec City	Charlottetown
Kelowna	Winnipeg	Ottawa	Halifax	Summerside
Prince George	London	Thunder Bay	Moncton	
Calgary	Hamilton	Sudbury	Saint John	
Edmonton	Toronto	Windsor	Dartmouth	



Fibergrate Composite Structures Inc. believes the information contained here to be true and accurate. Fibergrate makes no warranty, expressed or implied, based on this literature and assumes no responsibility for the consequential or incidental damages in the use of these products and systems described, including any warranty of merchantability or fitness. Information contained here can be for evaluation only. The marks and trade names appearing herein, whether registered or unregistered, are the property of Fibergrate Composite Structures Inc.

Fibergrate
Composite Structures